

COMTELCO

Technical Specification

BS100U

75-140 MHz Unity Gain

BASE STATION ANTENNAS

Reliable Performance: Rated at 250 watts and unity gain, you can expect years of continuous service.

Rugged Construction: The radiating elements are supported internally and constructed of copper alloy. They are welded and/or soldered to prevent any intermodulation. They are then encased in a fiberglass radome for total environmental protection.

Weatherproof: The fiberglass radome is ultraviolet inhibited. The heavy wall aluminum mounting sleeve is epoxy coated for superior weather protection.

Lightweight: These antennas are lightweight at less than 6 lbs. but are designed to easily withstand winds of over 125 MPH.

Simple Installation: Using the optional BSMNT2 mounting kit, installation takes only minutes.

ELECTRICAL SPECIFICATIONS:

FREQUENCY RANGE: 75MHz – 140MHz
VSWR: <2.0:1
POWER RATING: 250 watts
IMPEDANCE: 50 ohms
VERT. BEAMWIDTH: 75°

MECHANICAL SPECIFICATIONS:

RADIATOR: Internal copper alloy elements
RADOME: 1" dia. white UV inhibited fiberglass
MOUNTING SLEEVE: 10" heavy wall epoxy coated
SLEEVE DIAMETER: 1.35"
TERMINATION: Female N standard, pigtail optional
ANTENNA LENGTH: 96" at lowest frequency
WEIGHT: 8 lbs.
FLAT PLATE AREA: .44 ft²
WIND RATING: 125 MPH
LATERAL THRUST: 29.7 lbs.



Vertical Pattern

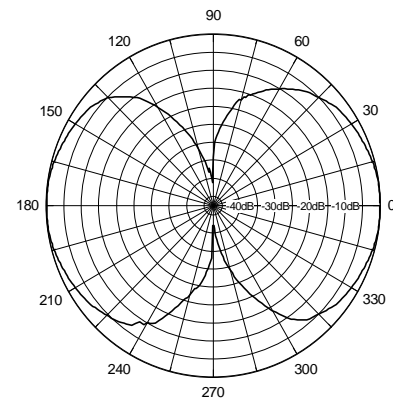

Horizontal Pattern

