

900-930MHz 3dBd, 5dBd & 6.5dBd Gain

BASE STATION ANTENNA

Reliable Performance: Rated at 250 watts, you can expect years of continuous service.

Rugged Construction: The radiating elements are supported internally and constructed of copper alloy. They are then encased in a fiberglass radome for total environmental protection.

Weatherproof: The fiberglass radome is ultraviolet inhibited. The heavy wall aluminum mounting sleeve is epoxy coated for superior weather protection.

Lightweight: These antennas are lightweight at less than 5 lbs. but are designed to easily withstand winds of over 100 MPH.

Simple Installation: Using the optional BSMNT2 mounting kit, installation takes only minutes.



ELECTRICAL SPECIFICATIONS:

| | |
|----------------------------|------------------------------|
| FREQUENCY: | 900-930MHz |
| GAIN: | XL3 3dBd XL5 5dBd XL7 6.5dBd |
| VERTICAL BEAMWIDTH: | XL3 40° XL5 30° XL7 15° |
| BANDWIDTH: | 30MHz@ <2.0:1 |
| POWER RATING: | 250 watts |
| IMPEDANCE: | 50 ohms |

MECHANICAL SPECIFICATIONS:

| | |
|-------------------------|------------------------------------|
| ANTENNA LENGTH: | XL3 36", XL5 50", XL7 62" |
| WEIGHT: | XL3 3 lbs., XL5 4 lbs., XL7 5 lbs. |
| RADIATOR: | Internal copper alloy elements |
| RADOME: | White UV inhibited fiberglass |
| MOUNTING SLEEVE: | Heavy wall epoxy coated aluminum |
| SLEEVE DIAMETER: | 1.35" |
| WIND SURVIVAL: | 125 MPH |

Vertical Pattern XL3

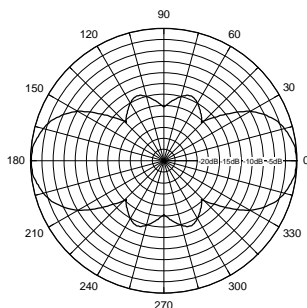

Vertical Pattern XL5

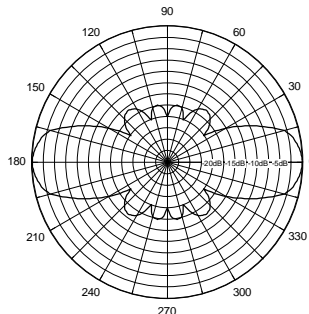

Vertical Pattern XL7

